

## CHAPTER 6

# ACTIVE BEACON NAVIGATION SYSTEMS

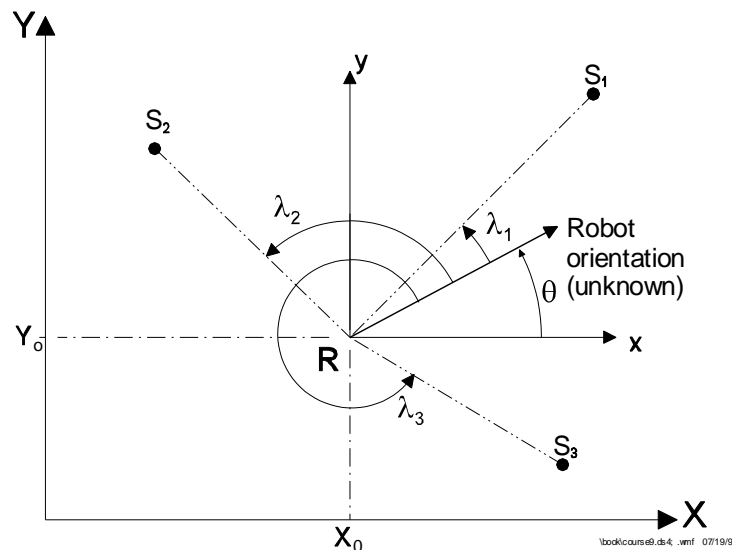
Active beacon navigation systems are the most common navigation aids on ships and airplanes. Active beacons can be detected reliably and provide very accurate positioning information with minimal processing. As a result, this approach allows high sampling rates and yields high reliability, but it does also incur high cost in installation and maintenance. Accurate mounting of beacons is required for accurate positioning. For example, land surveyors' instruments are frequently used to install beacons in a high-accuracy application [Maddox, 1994]. Kleeman [1992] notes that:

*"Although special beacons are at odds with notions of complete robot autonomy in an unstructured environment, they offer advantages of accuracy, simplicity, and speed - factors of interest in industrial and office applications, where the environment can be partially structured."*

One can distinguish between two different types of active beacon systems: *trilateration* and *triangulation*.

### Trilateration

Trilateration is the determination of a vehicle's position based on distance measurements to known beacon sources. In trilateration navigation systems there are usually three or more transmitters mounted at known locations in the environment and one receiver on board the robot. Conversely, there may be one transmitter on board and the receivers are mounted on the walls. Using time-of-flight information, the system computes the distance between the stationary transmitters and the onboard receiver. *Global Positioning Systems* (GPS), discussed in Section 3.1, are an example of trilateration. Beacon systems based on ultrasonic sensors (see Sec. 6.2, below) are another example.



**Figure 6.1:** The basic triangulation problem: a rotating sensor head measures the three angles  $\lambda_1$ ,  $\lambda_2$ , and  $\lambda_3$  between the vehicle's longitudinal axes and the three sources  $S_1$ ,  $S_2$ , and  $S_3$ .

## Triangulation

In this configuration there are three or more active transmitters (usually infrared) mounted at known locations in the environment, as shown in Figure 6.1. A rotating sensor on board the robot registers the angles  $\lambda_1$ ,  $\lambda_2$ , and  $\lambda_3$  at which it “sees” the transmitter beacons relative to the vehicle's longitudinal axis. From these three measurements the unknown x- and y- coordinates and the unknown vehicle orientation  $\theta$  can be computed. Simple navigation systems of this kind can be built very inexpensively [Borenstein and Koren, 1986]. One problem with this configuration is that the active beacons need to be extremely powerful to insure omnidirectional transmission over large distances. Since such powerful beacons are not very practical it is necessary to focus the beacon within a cone-shaped propagation pattern. As a result, beacons are not visible in many areas, a problem that is particularly grave because at least three beacons must be visible for triangulation. A commercially available sensor system based on this configuration (manufactured and marketed by Denning) was tested at the University of Michigan in 1990. The system provided an accuracy of approximately  $\pm 5$  centimeters ( $\pm 2$  in), but the aforementioned limits on the area of application made the system unsuitable for precise navigation in large open areas.

Triangulation methods can further be distinguished by the specifics of their implementation:

- a. **Rotating Transmitter-Receiver, Stationary Reflectors** In this implementation there is one rotating laser beam on board the vehicle and three or more stationary retroreflectors are mounted at known locations in the environment.
- b. **Rotating Transmitter, Stationary Receivers** Here the transmitter, usually a rotating laser beam, is used on board the vehicle. Three or more stationary receivers are mounted on the walls. The receivers register the incident beam, which may also carry the encoded azimuth of the transmitter.

For either one of the above methods, we will refer to the stationary devices as “*beacons*,” even though they may physically be receivers, retroreflectors, or transponders.

## 6.1 Discussion on Triangulation Methods

Most of the active beacon positioning systems discussed in Section 6.3 below include computers capable of computing the vehicle's position. One typical algorithm used for this computation is described in [Shoval et al., 1995], but most such algorithms are proprietary because the solutions are non-trivial. In this section we discuss some aspects of triangulation algorithms.

In general, it can be shown that triangulation is sensitive to small angular errors when either the observed angles are small, or when the observation point is on or near a circle which contains the three beacons. Assuming reasonable angular measurement tolerances, it was found that accurate navigation is possible throughout a large area, although error sensitivity is a function of the point of observation and the beacon arrangements [McGillem and Rappaport, 1988].

### 6.1.1 Three-Point Triangulation

Cohen and Koss [1992] performed a detailed analysis on three-point triangulation algorithms and ran computer simulations to verify the performance of different algorithms. The results are summarized as follows:

- The geometric triangulation method works consistently only when the robot is within the triangle formed by the three beacons. There are areas outside the beacon triangle where the geometric approach works, but these areas are difficult to determine and are highly dependent on how the angles are defined.
- The *Geometric Circle Intersection* method has large errors when the three beacons and the robot all lie on, or close to, the same circle.
- The *Newton-Raphson* method fails when the initial guess of the robot's position and orientation is beyond a certain bound.
- The heading of at least two of the beacons was required to be greater than 90 degrees. The angular separation between any pair of beacons was required to be greater than 45 degrees.

In summary, it appears that none of the above methods alone is always suitable, but an intelligent combination of two or more methods helps overcome the individual weaknesses.

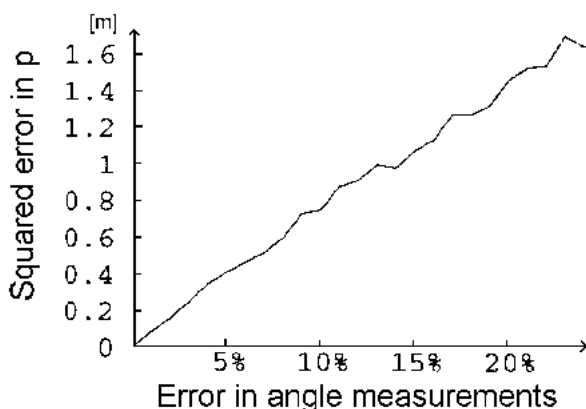
Yet another variation of the triangulation method is the so-called *running fix*, proposed by Case [1986]. The underlying principle of the running fix is that an angle or range obtained from a beacon at time  $t-1$  can be utilized at time  $t$ , as long as the cumulative movement vector recorded since the reading was obtained is added to the position vector of the beacon, thus creating a *virtual* beacon.

### 6.1.2 Triangulation with More Than Three Landmarks

Betke and Gurvits [1994] developed an algorithm, called the *Position Estimator*, that solves the general triangulation problem. This problem is defined as follows: given the global position of  $n$  landmarks and corresponding angle measurements, estimate the position of the robot in the global coordinate system. Betke and Gurvits represent the  $n$  landmarks as complex numbers and formulate the problem as a set of linear equations. By contrast, the traditional law-of-cosines approach yields a set of non-linear equations. Betke and Gurvits also prove mathematically that their algorithm only fails when all landmarks are on a circle or a straight line. The algorithm estimates the robot's position in  $O(n)$  operations where  $n$  is the number of landmarks on a two-dimensional map.

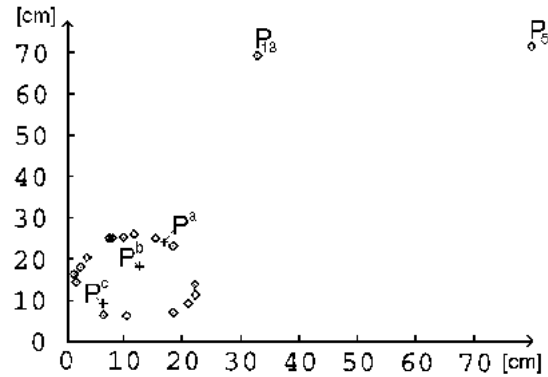
Compared to other triangulation methods, the *Position Estimator* algorithm has the following advantages: (1) the problem of determining the robot position in a noisy environment is linearized, (2) the algorithm runs in an amount of time that is a linear function of the number of landmarks, (3) the algorithm provides a position estimate that is close to the actual robot position, and (4) large errors ("outliers") can be found and corrected.

Betke and Gurvits present results of a simulation for the following scenario: the robot is at the origin of the map, and the landmarks are randomly distributed in a  $10 \times 10$  meter ( $32 \times 32$  ft) area (see Fig. 6.2). The robot is at the corner of this area. The distance between a landmark and the robot is at most 14.1 meters



**Figure 6.2:** Simulation results using the algorithm *Position Estimator* on an input of noisy angle measurements. The squared error in the position estimate  $p$  (in meters) is shown as a function of measurement errors (in percent of the actual angle). (Reproduced and adapted with permission from [Betke and Gurvits, 1994].)

(46 ft) and the angles are at most 45 degrees. The simulation results show that large errors due to misidentified landmarks and erroneous angle measurements can be found and discarded. Subsequently, the algorithm can be repeated without the outliers, yielding improved results. One example is shown in Figure 6.3, which depicts simulation results using the algorithm *Position Estimator*. The algorithm works on an input of 20 landmarks (not shown in Figure 6.3) that were randomly placed in a  $10 \times 10$  meters ( $32 \times 32$  ft) workspace. The simulated robot is located at  $(0, 0)$ . Eighteen of the landmarks were simulated to have a one-percent error in the angle measurement and two of the landmarks were simulated to have a large 10-percent angle measurement error. With the angle measurements from 20 landmarks the *Position Estimator* produces 19 position estimates  $p_1 - p_{19}$  (shown as small blobs in Figure 6.3). Averaging these 19 estimates yields the computed robot position. Because of the two landmarks with large angle measurement errors two position estimates are bad:  $p_5$  at  $(79 \text{ cm}, 72 \text{ cm})$  and  $p_{18}$  at  $(12.5 \text{ cm}, 18.3 \text{ cm})$ . Because of these poor position estimates, the resulting centroid (average) is at  $P^a = (17 \text{ cm}, 24 \text{ cm})$ . However, the *Position Estimator* can identify and exclude the two outliers. The centroid calculated without the outliers  $p_5$  and  $p_{18}$  is at  $P^b = (12.5 \text{ cm}, 18.3 \text{ cm})$ . The final position estimate after the *Position Estimator* is applied again on the 18 “good” landmarks (i.e., without the two outliers) is at  $P^c = (6.5 \text{ cm}, 6.5 \text{ cm})$ .



**Figure 6.3:** Simulation results showing the effect of outliers and the result of removing the outliers. (Reproduced and adapted with permission from [Betke and Gurvits, 1994].)

## 6.2 Ultrasonic Transponder Trilateration

*Ultrasonic trilateration schemes* offer a medium- to high-accuracy, low-cost solution to the position location problem for mobile robots. Because of the relatively short range of ultrasound, these systems are suitable for operation in relatively small work areas and only if no significant obstructions are present to interfere with wave propagation. The advantages of a system of this type fall off rapidly, however, in large multi-room facilities due to the significant complexity associated with installing multiple networked beacons throughout the operating area.

Two general implementations exist: 1) a single transducer transmitting from the robot, with multiple fixed-location receivers, and 2) a single receiver listening on the robot, with multiple fixed transmitters serving as beacons. The first of these categories is probably better suited to applications involving only one or at most a very small number of robots, whereas the latter case is basically unaffected by the number of passive receiver platforms involved (i.e., somewhat analogous to the Navstar GPS concept).

### 6.2.1 IS Robotics 2-D Location System

IS Robotics, Inc. [ISR], Somerville, MA, a spin-off company from MIT's renowned Mobile Robotics Lab, has introduced a beacon system based on an inexpensive ultrasonic trilateration system. This system allows their Genghis series robots to localize position to within 12.7 millimeters (0.5 in) over a 9.1×9.1 meter (30×30 ft) operating area [ISR, 1994]. The ISR system consists of a base station master hard-wired to two slave ultrasonic “pingers” positioned a known distance apart (typically 2.28 m — 90 in) along the edge of the operating area as shown in Figure 6.4. Each robot is equipped with a receiving ultrasonic transducer situated beneath a cone-shaped reflector for omnidirectional coverage. Communication between the base station and individual robots is accomplished using a Proxim spread-spectrum (902 to 928 MHz) RF link.

The base station alternately fires the two 40-kHz ultrasonic pingers every half second, each time transmitting a two-byte radio packet in broadcast mode to advise all robots of pulse emission. Elapsed time between radio packet reception and detection of the ultrasonic wave front is used to calculate distance between the robot's current position and the known location of the active beacon. Inter-robot communication is accomplished over the same spread-spectrum channel using a time-division-multiple-access scheme controlled by the base station. Principle sources of error include variations in the speed of sound, the finite size of the ultrasonic transducers, non-repetitive propagation delays in the electronics, and ambiguities associated with time-of-arrival detection. The cost for this system is \$10,000.

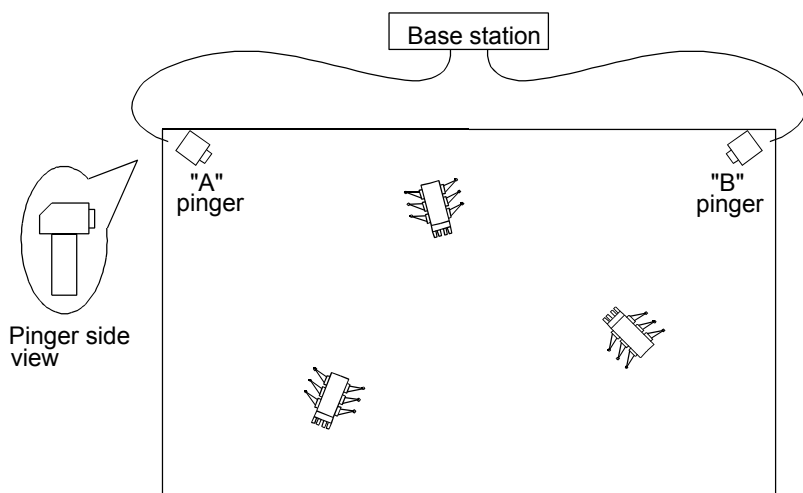


Figure 6.4: The ISR Genghis series of legged robots localize x-y position with a master/slave trilateration scheme using two 40 kHz ultrasonic “pingers.” (Adapted from [ISR, 1994].)

### 6.2.2 Tulane University 3-D Location System

Researchers at Tulane University in New Orleans, LA, have come up with some interesting methods for significantly improving the time-of-arrival measurement accuracy for ultrasonic transmitter-receiver configurations, as well as compensating for the varying effects of temperature and humidity. In the hybrid scheme illustrated in Figure 6.5, envelope peak detection is employed to establish the approximate time of signal arrival, and to consequently eliminate ambiguity interval problems for a more precise phase-measurement technique that provides final resolution [Figuroa and Lamancusa, 1992]. The desired 0.025 millimeters (0.001 in) range accuracy required a time unit discrimination of 75 nanoseconds at the receiver, which can easily be achieved using fairly simplistic phase measurement circuitry, but only within the interval of a single wavelength. The actual distance from transmitter to receiver is the summation of some integer number of wavelengths (determined by the

coarse time-of-arrival measurement) plus that fractional portion of a wavelength represented by the phase measurement results.

Details of this time-of-arrival detection scheme and associated error sources are presented by Figueroa and Lamancusa [1992]. Range measurement accuracy of the prototype system was experimentally determined to be 0.15 millimeters (0.006 in) using both threshold adjustments (based on peak detection) and phase correction, as compared to 0.53 millimeters (0.021 in) for threshold adjustment alone. These high-accuracy requirements were necessary for an application that involved tracking the end-effector of a 6-DOF industrial robot [Figueroa et al, 1992]. The system incorporates seven 90-degree Massa piezoelectric transducers operating at 40 kHz, interfaced to a 33 MHz IBM-compatible PC. The general position-location strategy was based on a trilateration method developed by Figueroa and Mohegan [1994].

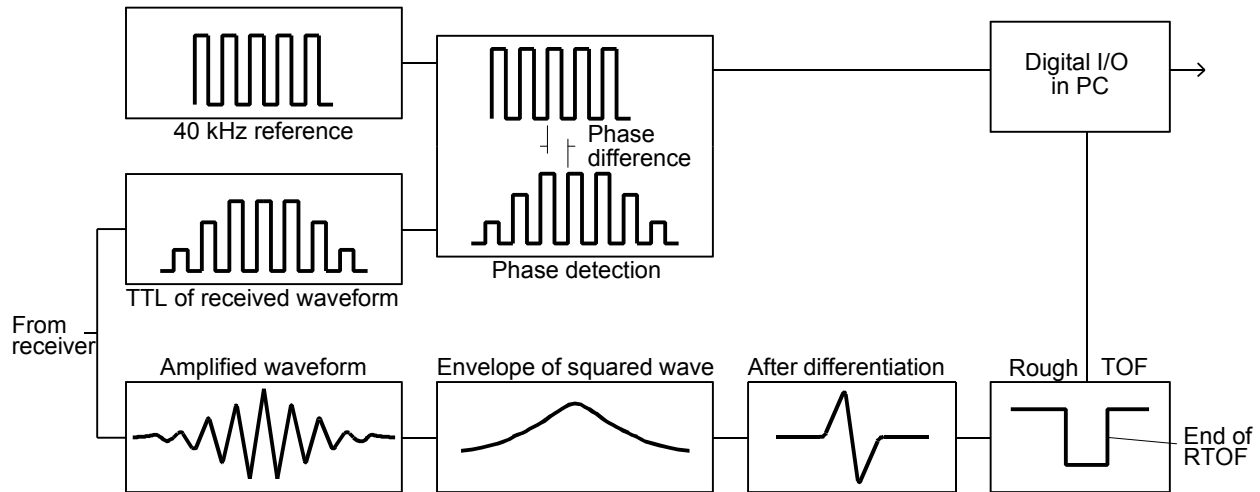


Figure 6.5: A combination of threshold adjusting and phase detection is employed to provide higher accuracy in time-of-arrival measurements in the Tulane University ultrasonic position-location system [Figueroa and Lamancusa, 1992].

The set of equations describing time-of-flight measurements for an ultrasonic pulse propagating from a mobile transmitter located at point  $(u, v, w)$  to various receivers fixed in the inertial reference frame can be listed in matrix form as follows [Figueroa and Mohegan, 1994]:

$$\begin{Bmatrix} (t_1 - t_d)^2 \\ (t_2 - t_d)^2 \\ * \\ * \\ * \\ (t_n - t_d)^2 \end{Bmatrix} = \begin{bmatrix} 1 & r_1^2 & 2x_1 & 2y_1 & 2z_1 \\ 1 & r_2^2 & 2x_2 & 2y_2 & 2z_2 \\ * & * & * & * & * \\ * & * & * & * & * \\ 1 & r_n^2 & 2x_n & 2y_n & 2z_n \end{bmatrix} \begin{Bmatrix} \frac{p^2}{c^2} \\ \frac{1}{c^2} \\ -\frac{u}{c^2} \\ -\frac{v}{c^2} \\ -\frac{w}{c^2} \end{Bmatrix} \quad (6.1)$$

where:

$t_i$	= measured time of flight for transmitted pulse to reach $i^{\text{th}}$ receiver
$t_d$	= system throughput delay constant
$r_i^2$	= sum of squares of $i^{\text{th}}$ receiver coordinates
$(x_i, y_i, z_i)$	= location coordinates of $i^{\text{th}}$ receiver
$(u, v, w)$	= location coordinates of mobile transmitter
$c$	= speed of sound
$p^2$	= sum of squares of transmitter coordinates.

The above equation can be solved for the vector on the right to yield an estimated solution for the speed of sound  $c$ , transmitter coordinates  $(u, v, w)$ , and an independent term  $p^2$  that can be compared to the sum of the squares of the transmitter coordinates as a checksum indicator [Figueroa and Mahajan, 1994]. An important feature of this representation is the use of an additional receiver (and associated equation) to enable treatment of the speed of sound itself as an unknown, thus ensuring continuous on-the-fly recalibration to account for temperature and humidity effects. (The system throughput delay constant  $t_d$  can also be determined automatically from a pair of equations for  $1/c^2$  using two known transmitter positions. This procedure yields two equations with  $t_d$  and  $c$  as unknowns, assuming  $c$  remains constant during the procedure.) A minimum of five receivers is required for an unambiguous three-dimensional position solution, but more can be employed to achieve higher accuracy using a least-squares estimation approach. Care must be taken in the placement of receivers to avoid singularities as defined by Mahajan [1992].

Figueroa and Mahajan [1994] report a follow-up version intended for mobile robot positioning that achieves 0.25 millimeters (0.01 in) accuracy with an update rate of 100 Hz. The prototype system tracks a TRC *LabMate* over a 2.7×3.7 meter (9×12 ft) operating area with five ceiling-mounted receivers and can be extended to larger floor plans with the addition of more receiver sets. An RF link will be used to provide timing information to the receivers and to transmit the subsequent x-y position solution back to the robot. Three problem areas are being further investigated to increase the effective coverage and improve resolution:

- Actual transmission range does not match the advertised operating range for the ultrasonic transducers, probably due to a resonant frequency mismatch between the transducers and electronic circuitry.
- The resolution of the clocks (6 MHz) used to measure time of flight is insufficient for automatic compensation for variations in the speed of sound.
- The phase-detection range-measurement correction sometimes fails when there is more than one wavelength of uncertainty. This problem can likely be solved using the frequency division scheme described by Figueroa and Barbieri [1991].

### 6.3 Optical Positioning Systems

Optical positioning systems typically involve some type of scanning mechanism operating in conjunction with fixed-location references strategically placed at predefined locations within the operating environment. A number of variations on this theme are seen in practice [Everett, 1995]:

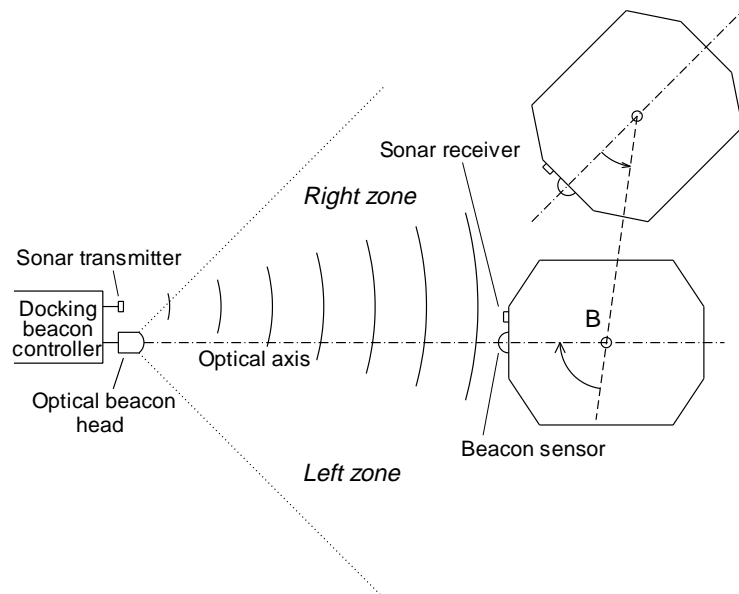
- Scanning detectors with fixed active beacon emitters.
- Scanning emitter/detectors with passive retroreflective targets.
- Scanning emitter/detectors with active transponder targets.
- Rotating emitters with fixed detector targets.

One of the principal problems associated with optical beacon systems, aside from the obvious requirement to modify the environment, is the need to preserve a clear line of sight between the robot and the beacon. Preserving an unobstructed view is sometimes difficult if not impossible in certain applications such as congested warehouse environments. In the case of passive retroreflective targets, problems can sometimes arise from unwanted returns from other reflective surfaces in the surrounding environment, but a number of techniques exists for minimizing such interference.

### 6.3.1 Cybermotion Docking Beacon

The automated docking system used on the Cybermotion *Navmaster* robot incorporates the unique combination of a structured-light beacon (to establish bearing) along with a one-way ultrasonic ranging system (to determine standoff distance). The optical portion consists of a pair of near-infrared transceiver units, one mounted on the front of the robot and the other situated in a known position and orientation within the operating environment. These two optical transceivers are capable of full-duplex data transfer between the robot and the dock at a rate of 9600 bits per second. Separate modulation frequencies of 154 and 205 kHz are employed for the uplink and downlink respectively to eliminate crosstalk. Under normal circumstances, the dock-mounted transceiver waits passively until interrogated by an active transmission from the robot. If the interrogation is specifically addressed to the assigned ID number for that particular dock, the dock control computer activates the beacon transmitter for 20 seconds. (Dock IDs are jumper selectable at time of installation.)

Figure 6.6 shows the fixed-location beacon illuminating a 90-degree field of regard broken up into two uniquely identified zones, designated for purposes of illustration here as the *Left Zone* and *Right Zone*. An array of LED emitters in the beacon head is divided by a double-sided mirror arranged along the optical axis and a pair of lenses. Positive zone identification is initiated upon request from the robot in the form of a NAV Interrogation byte transmitted over the optical datalink. LEDs on opposite sides of the mirror respond to this *NAV Interrogation* with slightly different coded responses. The robot can thus determine its relative location with respect



**Figure 6.6:** The structured-light near-infrared beacon on the Cybermotion battery recharging station defines an optimal path of approach for the *K2A Navmaster* robot [Everett, 1995].



to the optical axis of the beacon based on the response bit pattern detected by the onboard receiver circuitry.

Once the beacon starts emitting, the robot turns in the appropriate direction and executes the steepest possible (i.e., without losing sight of the beacon) intercept angle with the beacon optical axis. Crossing the optical axis at point B is flagged by a sudden change in the bit pattern of the *NAV Response Byte*, whereupon the robot turns inward to face the dock. The beacon optical axis establishes the nominal path of approach and in conjunction with range offset information uniquely defines the robot's absolute location. This situation is somewhat analogous to a TACAN station [Dodington, 1989] but with a single defined radial.

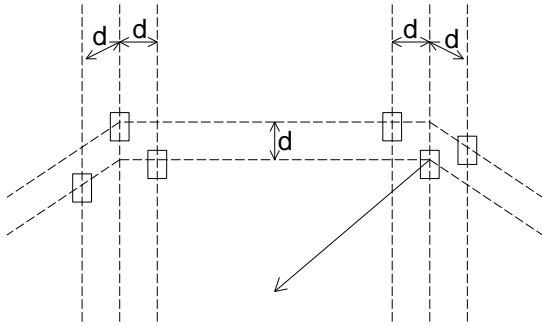
The offset distance from vehicle to dock is determined in rather elegant fashion by a dedicated non-reflective ultrasonic ranging configuration. This high-frequency (>200 kHz) narrow-beam (15°) sonar system consists of a piezoelectric transmitter mounted on the docking beacon head and a complimentary receiving transducer mounted on the front of the vehicle. A ranging operation is initiated upon receipt of the *NAV Interrogation Byte* from the robot; the answering *NAV Response Byte* from the docking beacon signals the simultaneous transmission of an ultrasonic pulse. The difference at the robot end between time of arrival for the *NAV Response Byte* over the optical link and subsequent ultrasonic pulse detection is used to calculate separation distance. This dual-transducer master/slave technique assures an unambiguous range determination between two well defined points and is unaffected by any projections on or around the docking beacon and/or face of the robot.

During transmission of a *NAV Interrogation Byte*, the left and right sides of the LED array located on the robot are also driven with uniquely identifiable bit patterns. This feature allows the docking beacon computer to determine the robot's actual heading with respect to the nominal path of approach. Recall the docking beacon's structured bit pattern establishes (in similar fashion) the side of the vehicle centerline on which the docking beacon is located. This heading information is subsequently encoded into the *NAV Response Byte* and passed to the robot to facilitate course correction. The robot closes on the beacon, halting at the defined stop range (not to exceed 8 ft) as repeatedly measured by the docking sonar. Special instructions in the path program can then be used to reset vehicle heading and/or position.

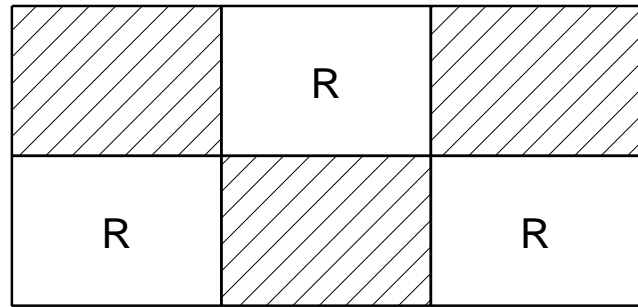
### 6.3.2 *Hilare*

Early work incorporating passive beacon tracking at the *Laboratoire d'Automatique et d'Analyse des Systemes*, Toulouse, France, involved the development of a navigation subsystem for the mobile robot *Hilare* [Banzil et al., 1981]. The system consisted of two near-infrared emitter/detectors mounted with a 25 centimeters (10 in) vertical separation on a rotating mast, used in conjunction with passive reflective beacon arrays at known locations in three corners of the room.

Each of these beacon arrays was constructed of retroreflective tape applied to three vertical cylinders, which were then placed in a recognizable configuration as shown in Figure 6.7. One of the arrays was inverted so as to be uniquely distinguishable for purposes of establishing an origin. The cylinders were vertically spaced to intersect the two planes of light generated by the rotating optical axes of the two emitters on the robot's mast. A detected reflection pattern as in Figure 6.8 confirmed beacon acquisition. Angular orientation relative to each of the retroreflective arrays was inferred from the stepper-motor commands that drove the scanning mechanism; lateral position was determined through simple triangulation.



**Figure 6.7:** Retroreflective beacon array configuration used on the mobile robot *Hilare*. (Adapted from [Banzil et al, 1981].)



**Figure 6.8:** A confirmed reflection pattern as depicted above was required to eliminate potential interference from other highly specular surfaces [Banzil et al., 1981].

### 6.3.3 NAMCO LASERNET

The NAMCO *LASERNET* beacon tracking system (Figure 6.9) employs retroreflective targets distributed throughout the operating area of an automated guided vehicle (AGV) in order to measure range and angular position (Figure 6.10). A servo-controlled rotating mirror pans a near-infrared laser beam through a horizontal arc of 90 degrees at a 20 Hz update rate. When the beam sweeps across a target of known dimensions, a return signal of finite duration is sensed by the detector. Since the targets are all the same size, the signal generated by a close target will be of longer duration than that from a distant one.

Angle measurement is initiated when the scanner begins its sweep from right to left; the laser strikes an internal synchronization photodetector that starts a timing sequence. The beam is then panned across the scene until returned by a retroreflective target in the field of view. The reflected signal is detected by the sensor, terminating the timing sequence (Fig. 6.11). The elapsed time is used to calculate the angular position of the target in the equation [NAMCO, 1989]

$$\theta = Vt_b - 45^\circ \quad (6.2)$$

where

$\theta$  = target angle

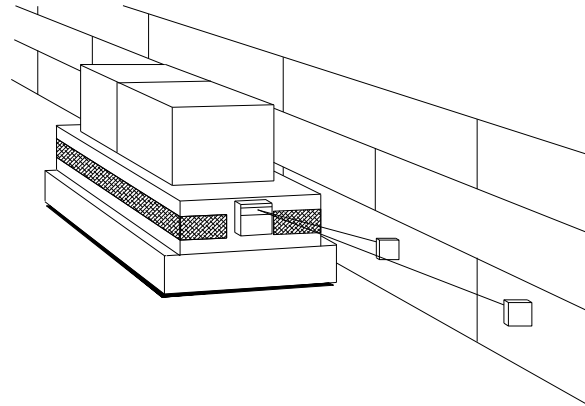
$V$  = scan velocity (7,200°/s)

$T_b$  = time between scan initiation and target detection.

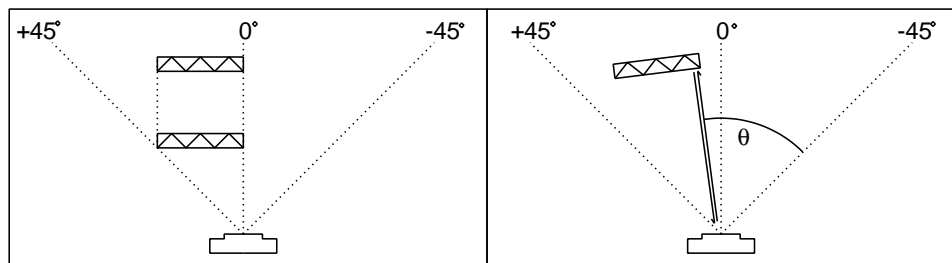


**Figure 6.9:** The *LASERNET* beacon tracking system. (Courtesy of Namco Controls Corp.)

This angle calculation determines either the leading edge of the target, the trailing edge of the target, or the center of the target, depending upon the option selected within the *LASERNET* software option list. The angular accuracy is  $\pm 1$  percent, and the angular resolution is 0.1 degrees for the analog output; accuracy is within  $\pm 0.05$  percent with a resolution of 0.006 degrees when the RS-232 serial port is used. The analog output is a voltage ranging from 0 to 10 V over the range of  $-45$  to  $+45$  degrees, whereas the RS-232 serial port reports a proportional “count value” from 0 to 15360 over this same range. The system costs \$3,400 in its basic configuration, but it has only a limited range of 15 meters (50 ft).



**Figure 6.10:** The LASERNET system can be used with projecting wall-mounted targets to guide an AGV at a predetermined offset distance. (Courtesy of NAMCO Controls.)

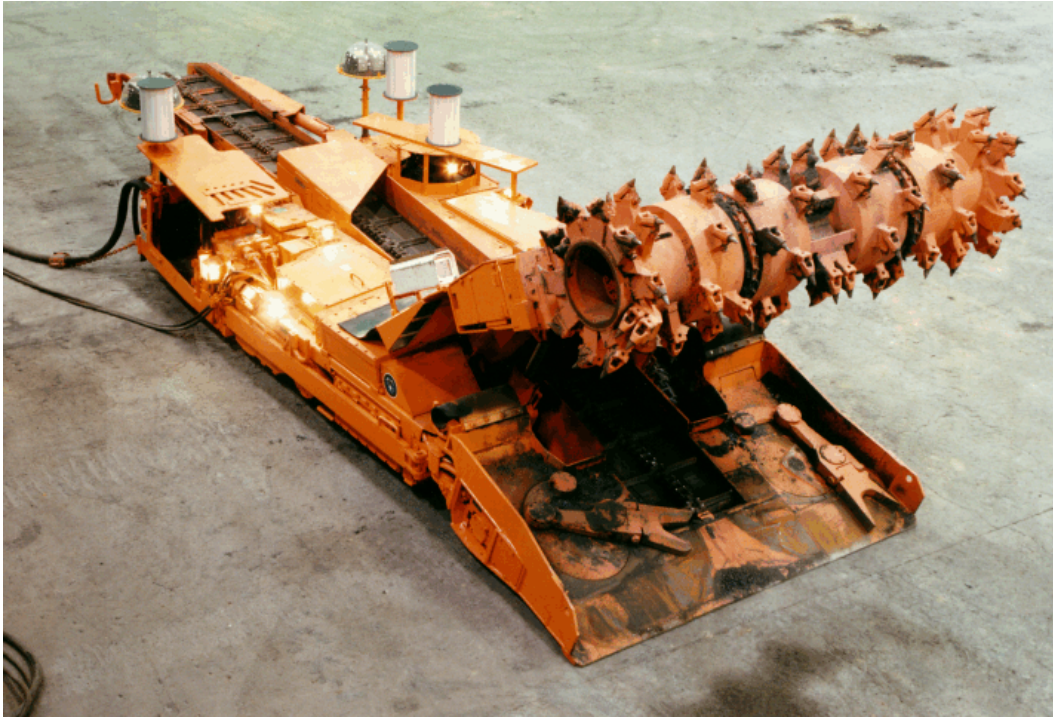


**Figure 6.11:** a. The perceived width of a retroreflective target of known size is used to calculate range; b. while the elapsed time between sweep initiation and leading edge detection yields target bearing. (Courtesy of NAMCO Controls).

### 6.3.3.1 U.S. Bureau of Mines' application of the LaserNet sensor

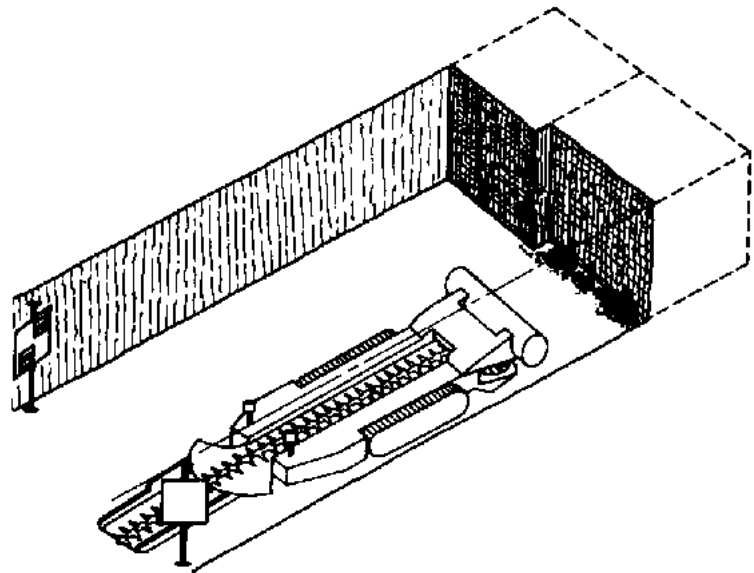
One robotics application of the NAMCO *LaserNet* is a research project conducted by Anderson [1991] at the U.S. Bureau of Mines. In this project the feasibility of automating the motion of a *continuous mining* (CM) machine. One such CM is the Joy 16CM shown in Fig. 6.12. The challenge with a CM is not speed, but vibration. During operation the cylindrical cutting device in front of the machine (see Fig. 6.13) cuts coal from the surface and a conveyor belt moves the coal backward for further processing. This and related activities generate a considerable amount of vibration. Another challenge in this mining application is the stringent requirement for high accuracy. High accuracy is required since even small position and orientation errors cause non-optimal cutting conditions that result in sub-optimal production yield.

The researchers at the U.S. Bureau of Mines installed two cylindrical retroreflective targets on the tail-end of the CM, while two LaserNet sensors were mounted on tripods at the entryway to the mine (see Fig. 6.13). One of the reported difficulties with this setup was the limited range of the early-model *LaserNet* sensor used in this experiment: 10.67 meter (35 ft) radially with a  $110^\circ$  field-of-view. The newer LaserNet LN120 (described in Section 6.3.3, above) has an improved range of 15.24 meter (50 ft). Another problem encountered in this application was the irregularity of the floor. Because of these irregularities the stationary scanners' beams would sometimes sweep beneath or above the retroreflective targets on the CM.



**Figure 6.13:** Front view of the Joy 16CM continuous mining machine at the U.S. Bureau of Mines' test facility. Cylindrical retroreflective targets are mounted on the tail (Courtesy of Anderson [1991].)

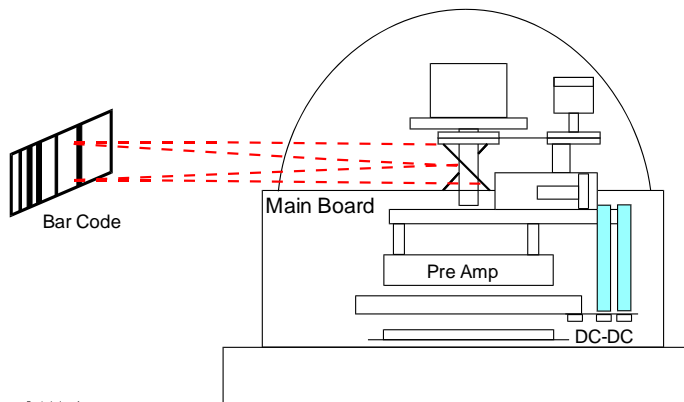
Besides the above mentioned technical difficulties the LaserNet system provided accurate data. In a series of test in which the CM moved on average one meter (3.3 ft) forward *while* cutting coal at the same time the resulting average error in translation was well below one centimeter. In a series of rotational movements of 7 to 15° the average measurement error was 0.3°. It should be emphasized that the *LaserNet* system proved robust in the presence of substantial vibrations.



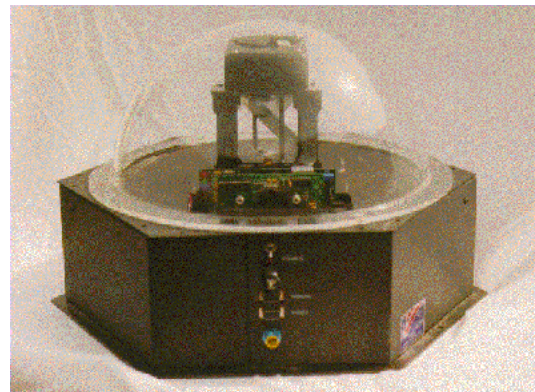
**Figure 6.13:** Schematic view of the Joy 16CM with two retroreflective targets and two LaserNav beacons/sensors in the entryway. (Courtesy of Anderson, [1991].)

### 6.3.4 Denning Branch International Robotics *LaserNav* Position Sensor

Denning Branch International Robotics [DBIR], Pittsburgh, PA, offers a laser-based scanning beacon system that computes vehicle position and heading out to 183 meters (600 ft) using cooperative electronic transponders, called *active targets*. A range of 30.5 meters (100 ft) is achieved with simple reflectors (passive targets). The *LaserNav Intelligent Absolute Positioning Sensor*, shown in Figures 6.14 and 6.15, is a non-ranging triangulation system with an absolute bearing accuracy of 0.03 degrees at a scan rate of 600 rpm. The fan-shaped beam is spread 4 degrees vertically to ensure target detection at long range while traversing irregular floor surfaces, with horizontal divergence limited to 0.017 degrees. Each target can be uniquely coded so that the *LaserNav* can distinguish between up to 32 separate active or passive targets during a single scan. The vehicle's x-y position is calculated every 100 milliseconds. The sensor package weighs 4.4 kilograms (10 lb), measures 38 centimeters (15 in) high and 30 centimeters (12 in) in diameter, and has a power consumption of only 300 mA at 12 V. The eye-safe near-infrared laser generates a 1 mW output at a wavelength of 810 nanometers.



**Figure 6.14:** Schematics of the Denning Branch International Robotics *LaserNav* laser-based scanning beacon system. (Courtesy of Denning Branch International Robotics.)



**Figure 6.15:** Denning Branch International Robotics (DBIR) can see *active targets* at up to 183 meters (600 ft) away. It can identify up to 32 active or passive targets. (Courtesy of Denning Branch International Robotics.)

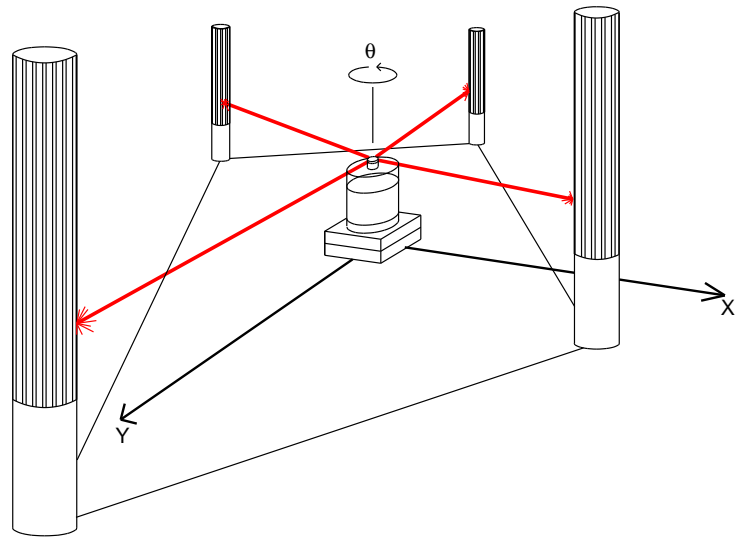
One potential source of problems with this device is the relatively small vertical divergence of the beam:  $\pm 2$  degrees. Another problem mentioned by the developer [Maddox, 1994] is that “*the LaserNav sensor ... is subject to rare spikes of wrong data.*” This undesirable phenomenon is likely due to reflections off shiny surfaces other than the passive reflectors. This problem affects probably all light-based beacon navigation systems to some degree. Another source of erroneous beacon readings is bright sunlight entering the workspace through wall openings.

### 6.3.5 TRC Beacon Navigation System

Transitions Research Corporation [TRC], Danbury, CT, has incorporated their LED-based *LightRanger*, discussed in Section 4.2, into a compact, low-cost navigational referencing system for open-area autonomous platform control. The TRC *Beacon Navigation System* calculates vehicle position and heading at ranges up to 24.4 meters (80 ft) within a quadrilateral area defined by four passive retroreflective beacons [TRC, 1994] (see Figure 6.16). A static 15-second unobstructed view

of all four beacons is required for initial acquisition and setup, after which only two beacons must remain in view as the robot moves about. At this time there is no provision to periodically acquire new beacons along a continuous route, so operation is currently constrained to a single zone roughly the size of a small building (i.e., 24.4×24.4 m or 80×80 ft).

System resolution is 120 millimeters (4¾ in) in range and 0.125 degrees in bearing for full 360-degree coverage in the horizontal plane. The scan unit (less processing electronics) is a cube approximately 100 millimeters (4 in) on a side, with a maximum 1-Hz update rate dictated by the 60-rpm scan speed. A dedicated 68HC11 microprocessor continuously outputs navigational parameters  $(x, y, \theta)$  to the vehicle's onboard controller via an RS-232 serial port. Power requirements are 0.5 A at 12 VDC and 0.1 A at 5 VDC. The system costs \$11,000.



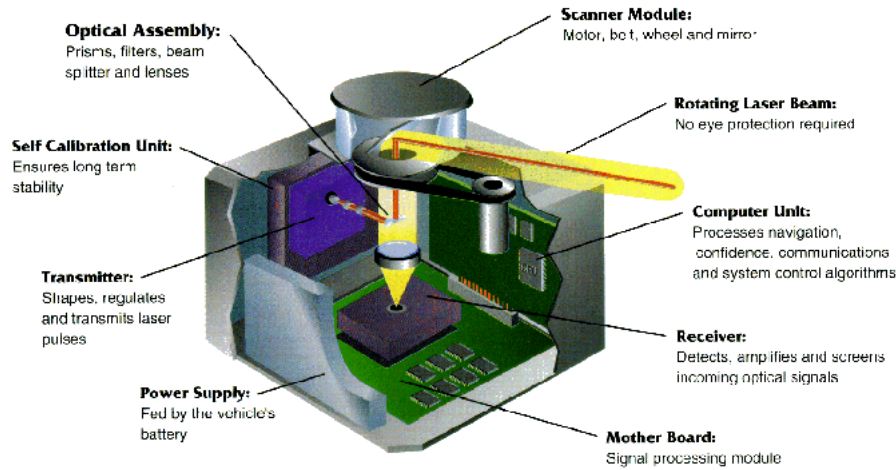
**Figure 6.16:** The TRC Beacon Navigation System calculates position and heading based on ranges and bearings to two of four passive beacons defining a quadrilateral operating area. (Courtesy of TRC.)

### 6.3.6 Siman Sensors and Intelligent Machines Ltd., *ROBOSENSE*

The *ROBOSENSE* is an eye-safe, scanning laser rangefinder developed by Siman Sensors & Intelligent Machines Ltd., Misgav, Israel (see Figure 6.17). The scanner illuminates retroreflective targets mounted on walls in the environment. It sweeps 360-degree segments in continuous rotation but supplies navigation data even while observing targets in narrower segments (e.g., 180°). The system's output are  $x$ - and  $y$ -coordinates in a global coordinate system, as well as heading and a confidence level. According to the manufacturer [Siman, 1995], the system is designed to operate under severe or adverse conditions, such as the partial occlusion of the reflectors. A rugged case houses the electro-optical sensor, the navigation computer, the communication module, and the power supply. *ROBOSENSE* incorporates a unique self-mapping feature that does away with the need for precise measurement of the targets, which is needed with other systems.

The measurement range of the *ROBOSENSE* system is 0.3 to 30 meters (1 to 100 ft). The position accuracy is 20 millimeters (¾ in) and the accuracy in determining the orientation is better than 0.17 degrees. The system can communicate with an onboard computer via serial link, and it updates the position and heading information at a rate of 10 to 40 Hz. *ROBOSENSE* navigates through areas that can be much larger than the system's range. This is done by dividing the whole site map into partial frames, and positioning the system within each frame in the global coordinate system. This method, called *Rolling Frames*, enables *ROBOSENSE* to cover practically unlimited area.

The power consumption of the *ROBOSENSE* system is less than 20 W at 24 VDC. The price for a single unit is \$12,800 and \$7,630 each for an order of three units.



**Figure 6.17:** The ROBOSENSE scanning laser rangefinder was developed by Siman Sensors & Intelligent Machines Ltd., Misgav, Israel. The system determines its own heading and absolute position with an accuracy of 0.17° and 20 millimeters (3/4 in), respectively. (Courtesy of Siman Sensors & Intelligent Machines.)

### 6.3.7 Imperial College Beacon Navigation System

Premi and Besant [1983] of the Imperial College of Science and Technology, London, England, describe an AGV guidance system that incorporates a vehicle-mounted laser beam rotating in a horizontal plane that intersects three fixed-location reference sensors as shown in Figure 6.18. The photoelectric sensors are arranged in collinear fashion with equal separation and are individually wired to a common FM transmitter via appropriate electronics so that the time of arrival of laser energy is relayed to a companion receiver on board the vehicle. A digitally coded identifier in the data stream identifies the activated sensor that triggered the transmission, thus allowing the onboard computer to measure the separation angles  $\alpha_1$  and  $\alpha_2$ .

AGV position  $P(x,y)$  is given by the equations [Premi and Besant, 1983]

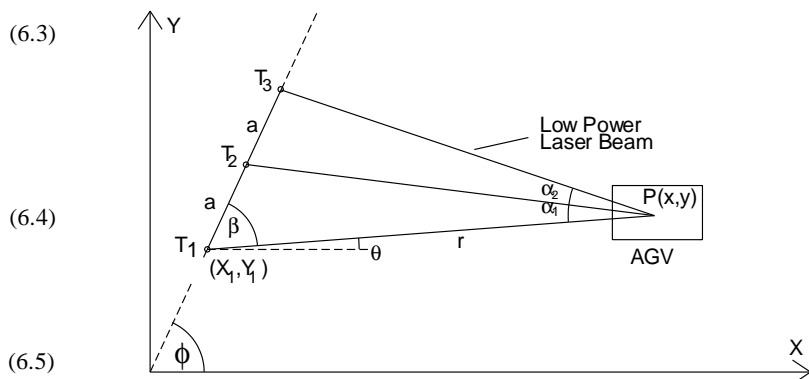
$$\begin{aligned} x &= x_1 + r\cos\theta \\ y &= y_1 + r\sin\theta \end{aligned} \tag{6.3}$$

where

$$r = \frac{a \sin(\alpha_1 + \beta)}{\sin\alpha_1} \tag{6.4}$$

$$\beta = \arctan \frac{2 \tan\alpha_1 \tan\alpha_2}{\tan\alpha_2 - \tan\alpha_1} - 1 \tag{6.5}$$

$$\theta = \phi - \beta \tag{6.6}$$



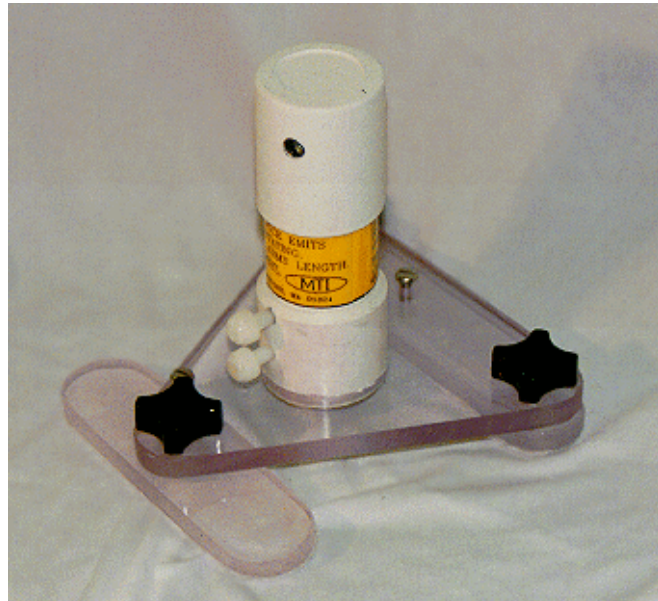
**Figure 6.18:** Three equidistant collinear photosensors are employed in lieu of retroreflective beacons in the Imperial College laser triangulation system for AGV guidance. (Adapted from [Premi and Besant, 1983].)

An absolute or indexed incremental position encoder that monitors laser scan azimuth is used to establish platform heading.

This technique has some inherent advantages over the use of passive retroreflective targets, in that false acquisition of reflective surfaces is eliminated, and longer ranges are possible since target reflectivity is no longer a factor. More robust performance is achieved through elimination of target dependencies, allowing a more rapid scan rate to facilitate faster positional updates. The one-way nature of the optical signal significantly reduces the size, weight, and cost of the onboard scanner with respect to that required for retroreflective beacon acquisition. Tradeoffs, however, include the increased cost associated with installation of power and communications lines and the need for significantly more expensive beacons. This can be a serious drawback in very-large-area installations, or scenarios where multiple beacons must be incorporated to overcome line-of-sight limitations.

### 6.3.8 MTI Research CONAC™

A similar type system using a predefined network of fixed-location detectors is currently being built and marketed by MTI Research, Inc., Chelmsford, MA [MTI]. MTI's *Computerized Opto-electronic Navigation and Control*<sup>1</sup> (CONAC) is a relatively low-cost, high-performance navigational referencing system employing a vehicle-mounted laser unit called *STRuctured Opto-electronic Acquisition Beacon* (STROAB), as shown in Figure 6.19. The scanning laser beam is spread vertically to eliminate critical alignment, allowing the receivers, called *Networked Opto-electronic Acquisition Datums* (NOADs) (see Figure 6.20), to be mounted at arbitrary heights (as illustrated in Figure 6.21). Detection of incident illumination by a NOAD triggers a response over the network to a host PC, which in turn calculates the implied angles  $\alpha_1$  and  $\alpha_2$ . An index sensor built into the STROAB generates a special rotation reference pulse to facilitate heading measurement. Indoor accuracy is on the order of centimeters or millimeters, and better than 0.1 degrees for heading.



**Figure 6.19:** A single STROAB beams a vertically spread laser signal while rotating at 3,000 rpm. (Courtesy of, MTI Research Inc.)

The reference NOADs are strategically installed at known locations throughout the area of interest, and daisy chained together with ordinary four-conductor modular telephone cable. Alternatively the NOADS can be radio linked to eliminate cable installation problems, as long as power is independently available to the various NOAD sites. STROAB acquisition range is sufficient to where three NOADS can effectively cover an area of 33,000 m<sup>2</sup> (over 8 acres) assuming no

<sup>1</sup> CONAC is a trademark of MTI.



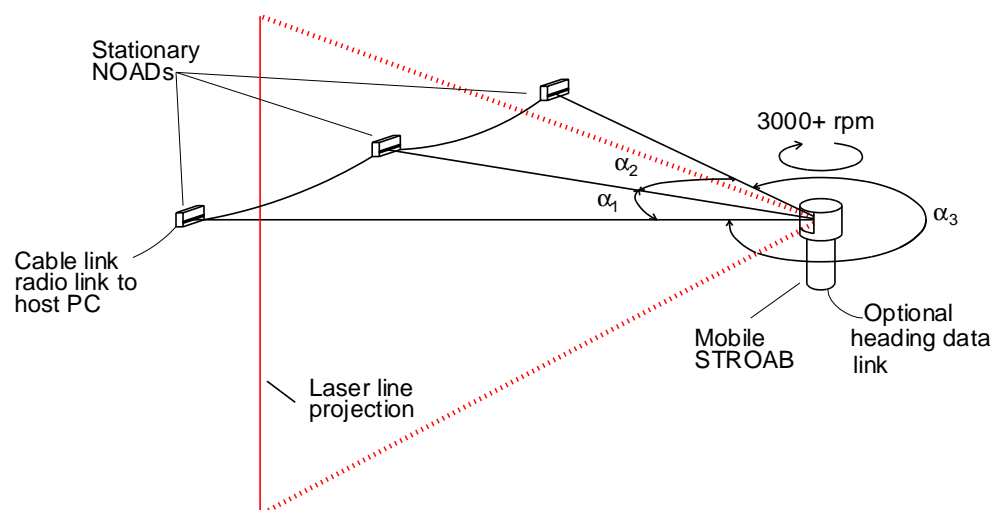
interfering structures block the view. Additional NOADS are typically employed to increase fault tolerance and minimize ambiguities when two or more robots are operating in close proximity. The optimal set of three NOADS is dynamically selected by the host PC, based on the current location of the robot and any predefined visual barriers. The selected NOADS are individually addressed over the network in accordance with assigned codes (set into DIP switches on the back of each device at time of installation).

An interesting and unconventional aspect of CONAC™ is that no fall-back dead-reckoning capability is incorporated into the system [MacLeod and Chiarella, 1993]. The 3,000 rpm angular rotation speed of the laser STROAB facilitates rapid position updates at a 25 Hz rate, which MTI claims is sufficient for safe automated transit at highway speeds, provided line-of-sight contact is preserved with at least three fixed NOADS. To minimize chances of occlusion, the lightweight (less than 250 g — 9 oz) STROAB is generally mounted as high as possible on a supporting mast.

The ability of the CONAC™ system was demonstrated in an intriguing experiment with a small, radio-controlled race car called *Scooter*. During this experiment, the *Scooter* achieved speeds greater than 6.1 m/s (20 ft/s) as shown by the *Scooter's* mid-air acrobatics in Figure 6.22. The small vehicle was equipped with a STROAB and programmed to race along the race course shown in Figure 6.23. The small boxes in Figure 6.23 represent the desired path, while the continuous line represents the



**Figure 6.20:** Stationary NOADS are located at known positions; at least two NOADS are networked and connected to a PC. (Courtesy of MTI Research, Inc.)

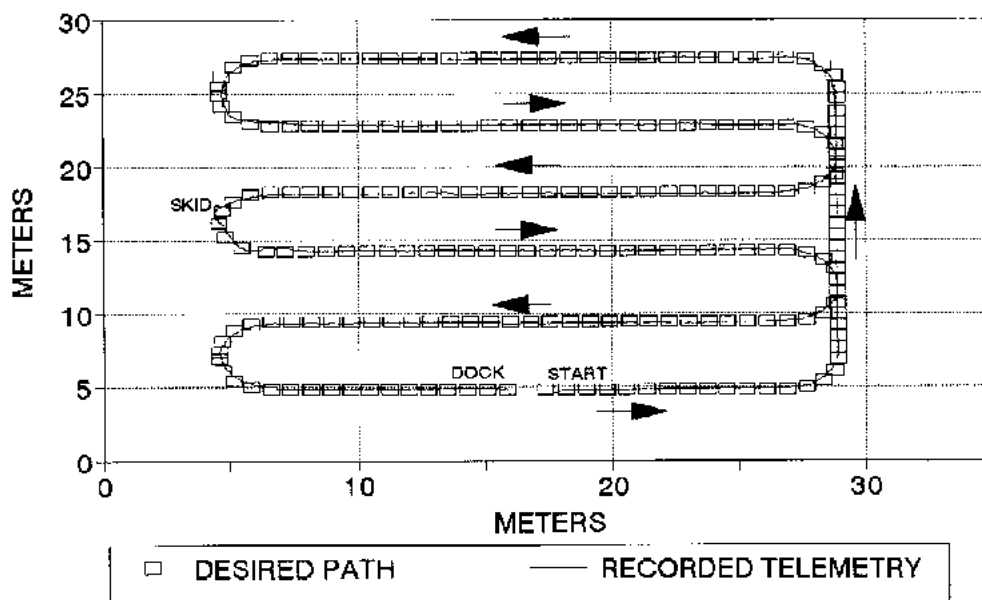


**Figure 6.21:** The Computerized Opto-electronic Navigation and Control (CONAC™) system employs an onboard, rapidly rotating and vertically spread laser beam, which sequentially contacts the networked detectors. (Courtesy of MTI Research, Inc.)

position of the vehicle during a typical run. 2,200 data points were collected along the 200 meter (650 ft) long path. The docking maneuver at the end of the path brought the robot to within 2 centimeters (0.8 in) of the desired position. On the tight turns, the *Scooter* decelerated to smoothly execute the hairpin turns.



**Figure 6.22:** MTI's *Scooter* zips through a race course; tight close-loop control is maintained even in mid-air and at speeds of up to 6.1 m/s (20 ft/s).

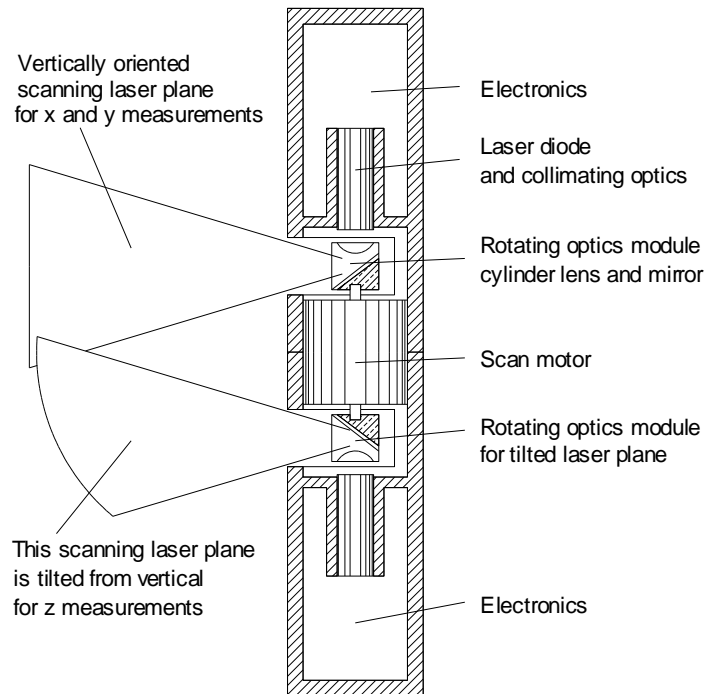


**Figure 6.23:** Preprogrammed race course and recorded telemetry of the *Scooter* experiment. Total length: 200 m (650 ft); 2200 data points collected. (Courtesy of MTI Research, Inc.)

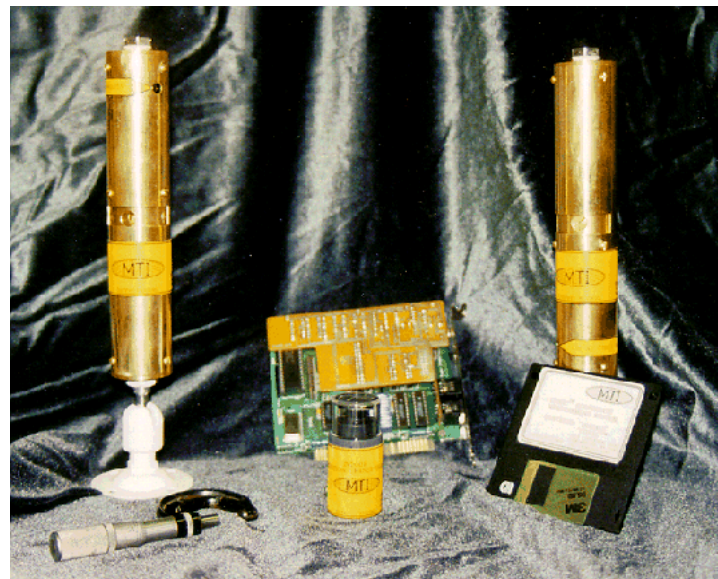
### CONAC™ Fixed Beacon System

A stationary active beacon system that tracks an omnidirectional sensor mounted on the robot is currently being sold to allow for tracking multiple units. (The original CONAC™ system allows only one beacon to be tracked at a given time.) The basic system consists of two synchronized stationary beacons that provide bearings to the mobile sensor to establish its x-y location. A hybrid version of this approach employs two lasers in one of the beacons, as illustrated in Figure 6.24, with the lower laser plane tilted from the vertical to provide coverage along the z-axis for three-dimensional applications. A complete two-dimensional indoor system is shown in Figure 6.25.

Long-range exterior position accuracy is specified as  $\pm 1.3$  millimeters ( $\pm 0.5$  in) and the heading accuracy as  $\pm 0.05$  degrees. The nominal maximum line-of-sight distance is 250 meters (780 ft), but larger distances can be covered with a more complex system. The system was successfully demonstrated in an outdoor environment when MacLeod engineers outfitted a Dodge caravan with electric actuators for steering, throttle, and brakes, then drove the unmanned vehicle at speeds up to 80 km/h (50 mph) [Baker, 1993]. MTI recently demonstrated the same vehicle at 108 km/h (65 mph). Absolute position and heading accuracies were sufficient to allow the Caravan to maneuver among parked vehicles and into a parking place using a simple AutoCad representation of the environment. Position computations are updated at a rate of 20 Hz. This system represents the current state-of-the-art in terms of active beacon positioning [Fox, 1993; Baker, 1993; Gunther, 1994]. A basic system with one STROAB and three NOADs costs on the order of \$4,000.



**Figure 6.24:** Simplified cross section view of the dual-laser position-location system now under development for tracking multiple mobile sensors in 3-D applications. (Courtesy of MTI Research, Inc.)



**Figure 6.25:** MTI's basic 2-D indoor package. A mobile position transponder (shown in lower center) detects the passing laser emissions generated by the two spread-out stationary laser beacons. (Courtesy of MTI Research, Inc.)

### 6.3.9 Spatial Positioning Systems, inc.: *Odyssey*

Spatial Positioning Systems, inc. [SPSi] of Reston, Virginia has developed and markets a high-accuracy 3-D positioning system called *Odyssey*. The Odyssey system was originally developed for the accurate surveying of construction sites and for retro-active three-dimensional modeling of buildings, etc. However, it appears that the system can be used for mobile robot operations quite easily.

The Odyssey system comprises two or more stationary laser transmitters (shown mounted on tripods, in Fig. 6.26) and a mobile optical receiver, which is shown mounted on top of the red-white receiving pole in the center of Fig. 6.26. The receiver is connected to a portable data logging device with real-time data output via RS-232 serial interface. In its originally intended hand-held mode of operation the surveyor holds the tip of the receiver-wand at a point of interest. The system records instantly the three-dimensional coordinates of that point (see Fig 6.27).

To set up the Odyssey system two or more transmitters must be placed at precisely known locations in the environment. Alternatively the accurate transmitter position can be computed in a reverse calibration procedure in which the receiver-wand is placed at four known positions. and the system Once the transmitters are located at known positions, one or more receivers can produce data points simultaneously, while being applied in the same environment.

The system has an accuracy of  $\pm 1 \text{ mm} + 100 \text{ ppm}$  (note: ppm stands for *parts in million*) over a range of up to 150 meters (500 ft). Thus, at a location 150 meters away from the transmitters the position accuracy would still be  $1 \text{ mm} + 100 \text{ ppm} \times 150 \text{ m} = 16 \text{ mm}$ . Additional technical specifications are listed in Table y. For mobile robot applications the Odyssey system may be somewhat pricy at roughly \$90,000, depending on system configuration.



**Figure 6.26:** The Odyssey positioning system comprises two laser beam transmitters and a pole- or wand-mounted receiver. (Courtesy of Spatial Positioning Systems, Inc.)

**Table 6.1:** Technical specifications for the *Odyssey* positioning system. (Courtesy of Spatial Positioning Systems, inc.)

Parameter	Value	Units
Horizontal accuracy	$\pm 1$ mm	
	0.04 in	
	+ 100 ppm	
Vertical accuracy	$\pm 1$ mm	
	0.04 inches	
	+ 100 ppm	
Outdoor receiver range	150 m	
	500 ft	
Indoor receiver range	75 m	
	250 ft	
Measurement rate	5 Hz	
Transmitter scan rate	50 Hz	
Transmitter field of view	$120 \times 30^\circ$	
Transmitter power	12 VDC	
	max. 4.0 A	
	steady-state 1.5 A	
Receiver power	12 VDC	
	max. 0.8 A	
	steady-state 0.3 A	
Transmitter dimensions	510x210 mm	
	x180 in	
	20x8x7	
Transmitter weight	11 kg	
	24 lbs	
Receiver weight	~4 kg	
	9 lbs	



**Figure 6.27:** In its originally intended hand-held mode of operation the surveyor places the tip of the wand-receiver at a point of interest to record that point's 3-D coordinates. (Courtesy of Spatial Positioning Systems, Inc.)

### 6.3.9 Lawnmower CALMAN

Larsson et al. [1994] from the University of Lulea, Sweden, have converted a large riding lawnmower to fully autonomous operation. This system, called *CALMAN*, uses an onboard rotating laser scanner to illuminate strategically placed vertical retroreflector stripes. These reflectors are attached to tree stems or vertical poles in the environment. Larsson et al. report experimental results from running the vehicle in a parking lot. According to these results, the vehicle had a positioning error of less than 2 centimeters (3/4 in) at speeds of up to 0.3 milliseconds (1 ft/s). The motion of the vehicle was stable at speeds of up to 1 m/s (3.3 ft/s) and became unstable at 1.5 m/s (5 ft/s).

## 6.4 Summary

We summarize the general characteristics of active beacon systems as follows:

- The environment needs to be modified, and some systems require electric outlets or battery maintenance for stationary beacons.
- A line of sight between transmitter and detector needs to be maintained, i.e., there must be at least two or three *visible* landmarks in the environment.
- Triangulation-based methods are subject to the limitations of triangulation as discussed by Cohen and Koss [1992].
- Active beacon systems have been proven in practice, and there are several commercial systems available using laser, infrared, and ultrasonic transducers.
- In practice, active beacon systems are the choice when high accuracy and high reliability are required.