

scala 1:50

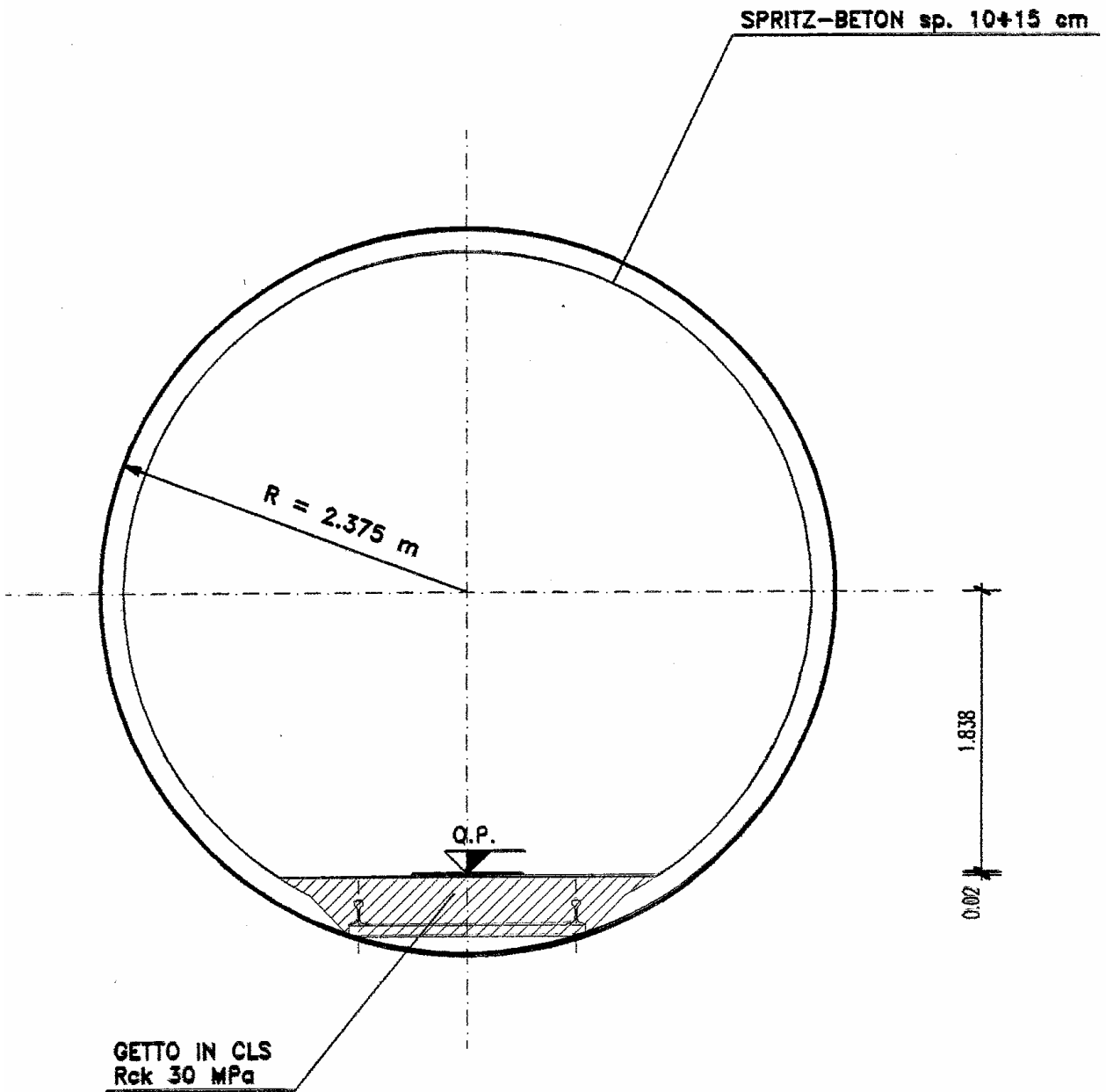

Scala delle velocità e scala delle portate di moto uniforme per condotta circolare avente:

- ▶ diametro $D = 4.09$ m;
- ▶ pendenza $i = 0.9604\text{‰}$;
- ▶ coefficiente di scabrezza di Chézy-Strickler $K_S = 80$ m^{1/3}/s;

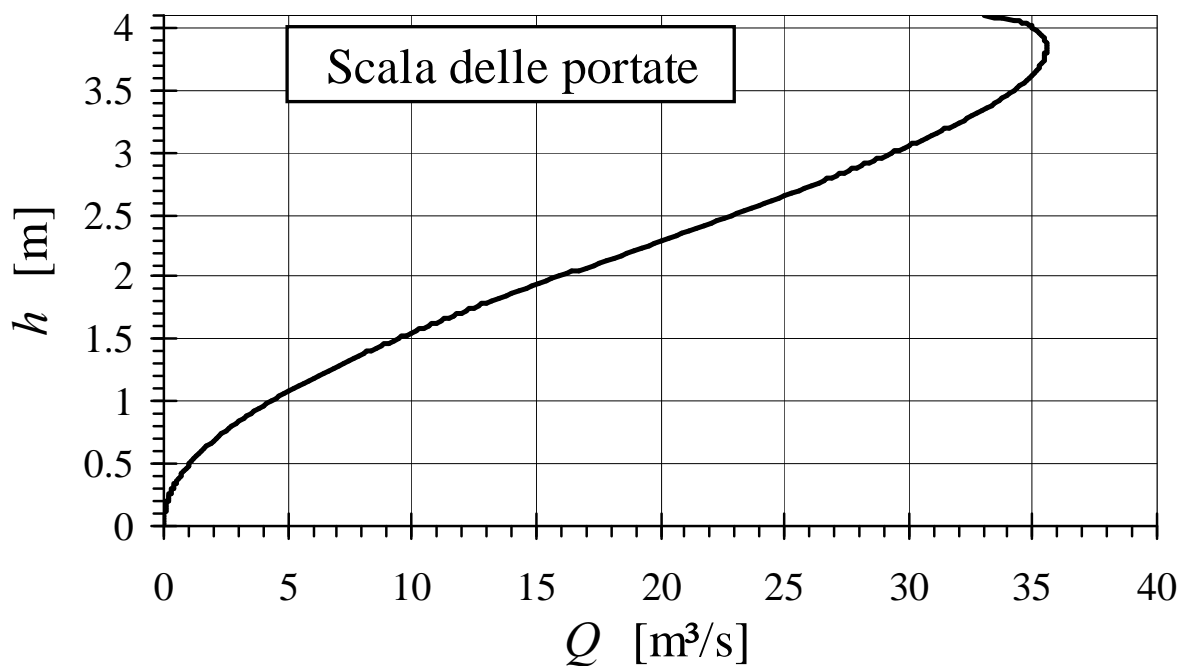
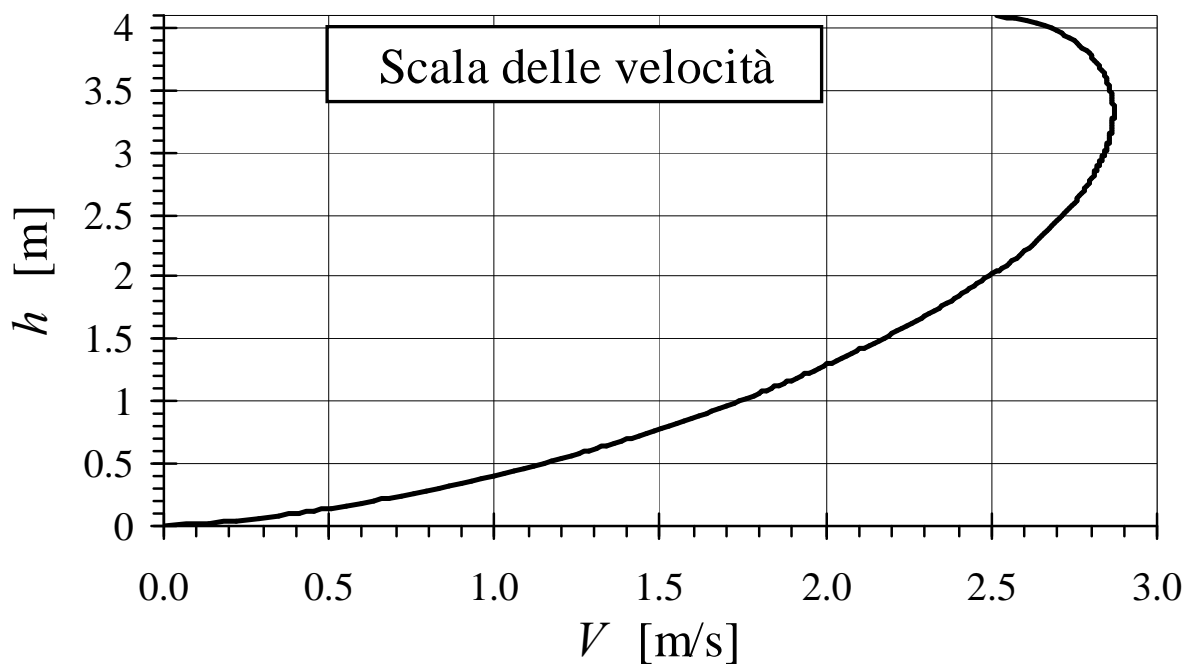

a) Sezione circolare

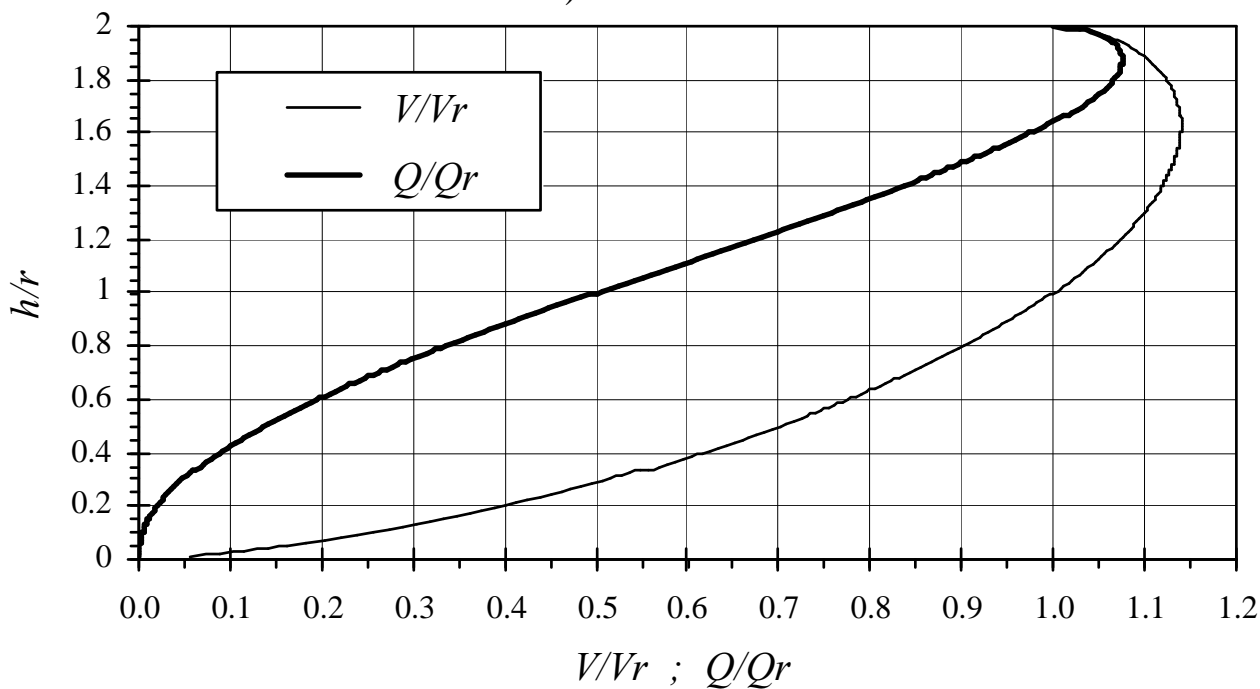

b) Sezione ovoidale cosiddetta "vecchio inglese"

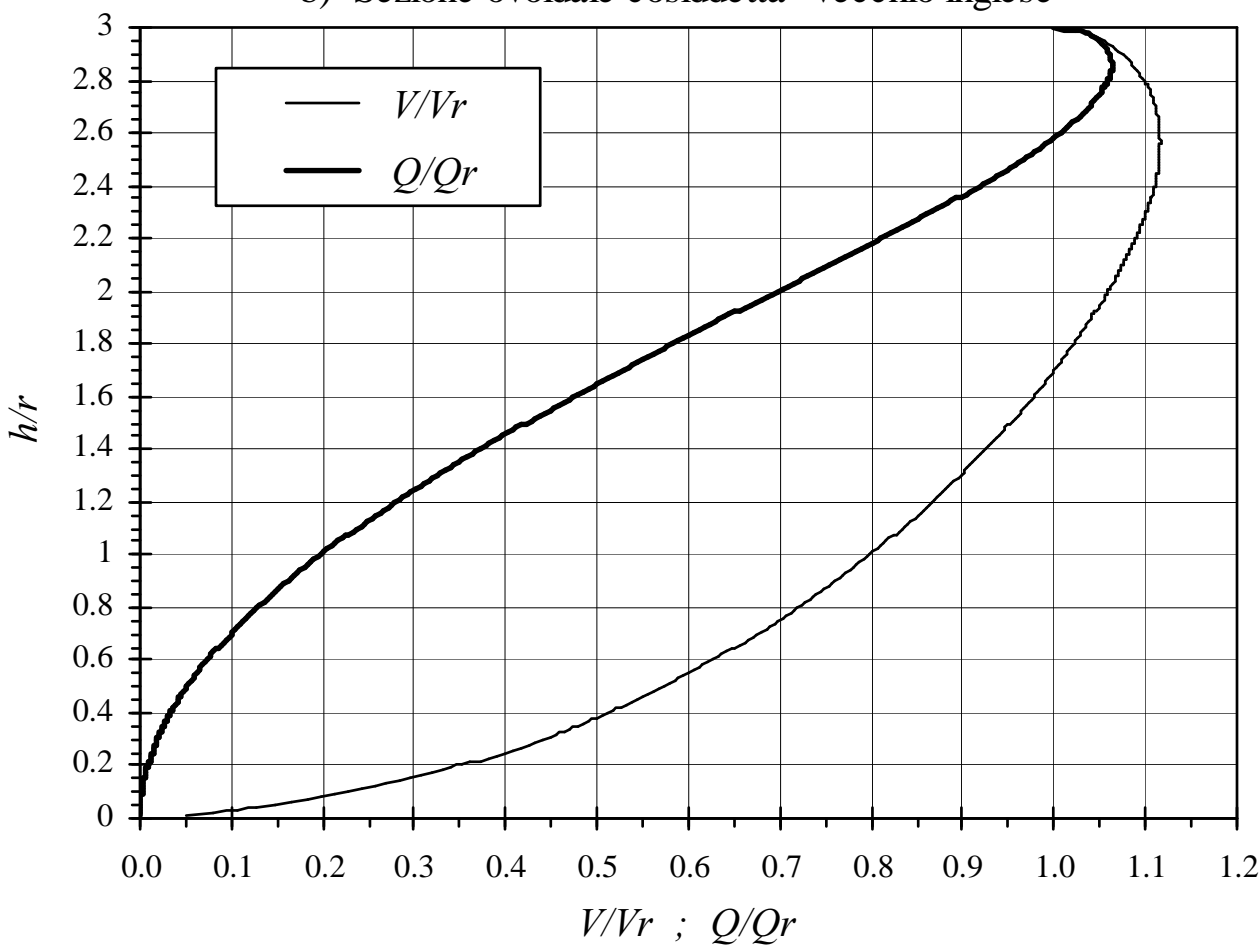

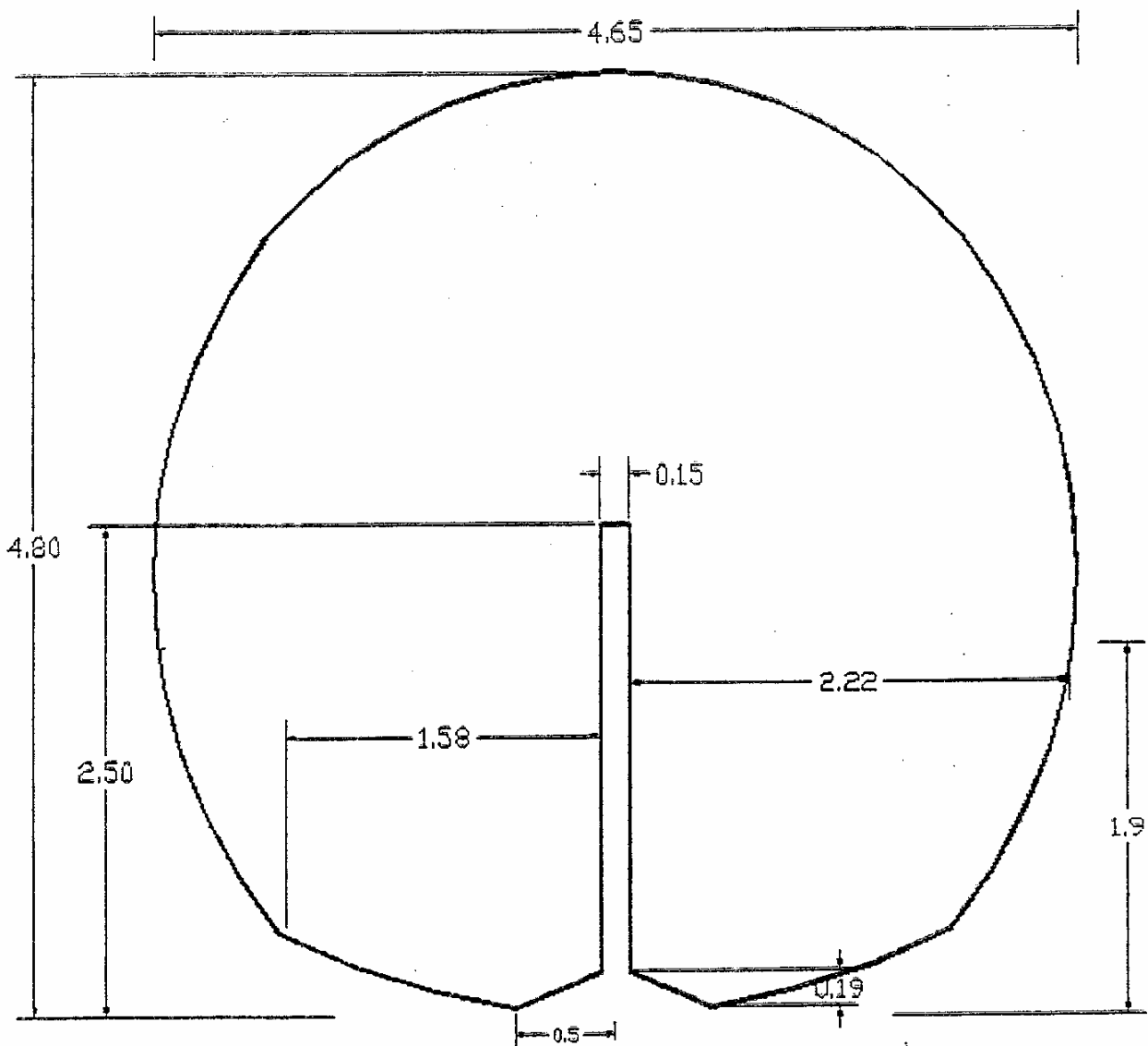

galleria ex-Casmez modificata

Emissario Ex-Casmez. Sezione modificata e senza sedimenti

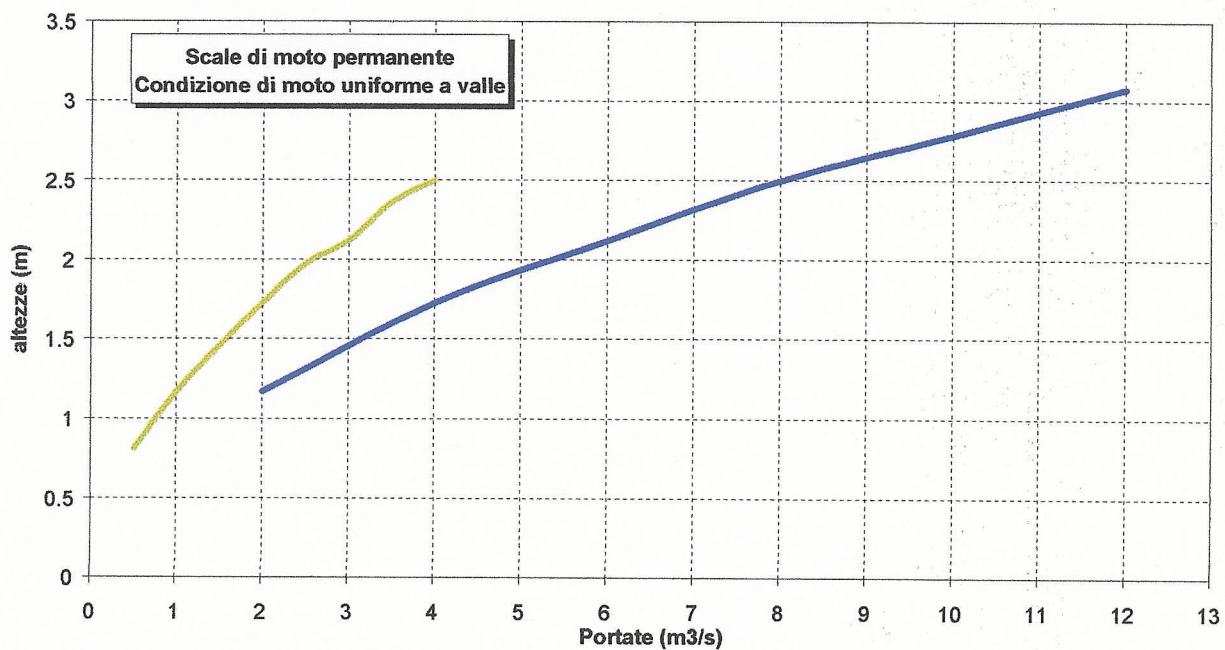
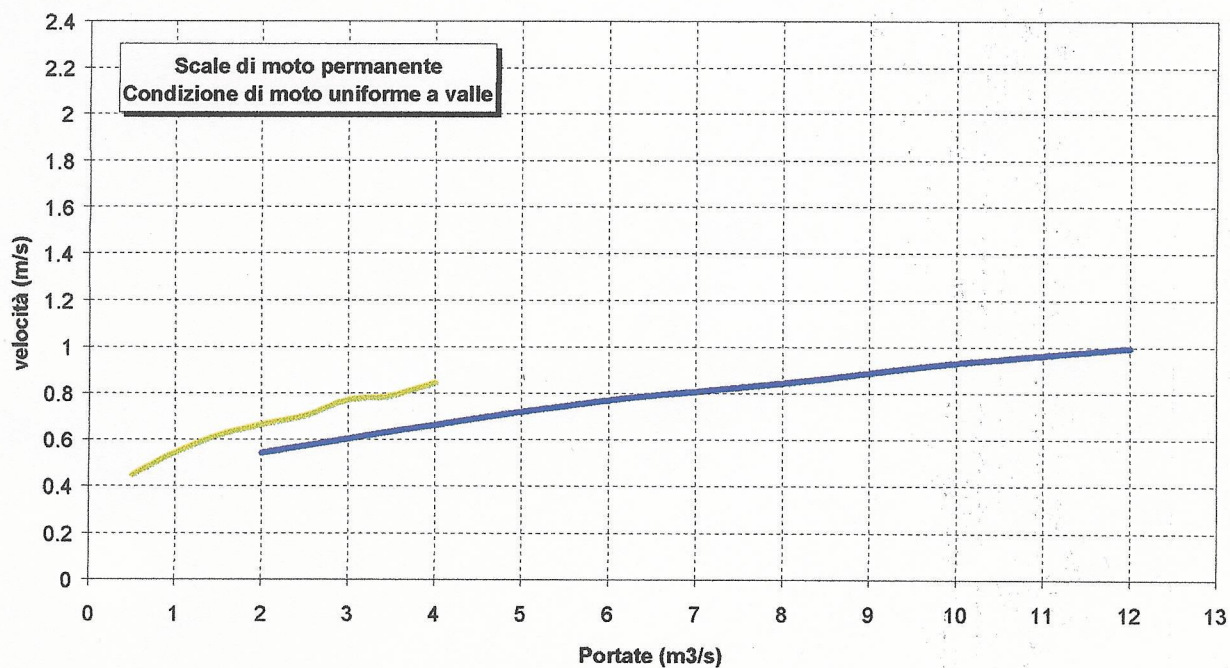

Sezione ex-Casmez modificata con deflusso confinato a metà sezione (in verde) e a sezione intera (in blu).